

VALVULAS CT



**A Spanish Specialist
In Ball Float Valve**





High Quality --- Patented Design Stainless Steel Ball Float Valve

Valvulas CT are a team specializing in the design and manufacture of high quality float valve in Spain. With over 25 years of experience, we provide innovative solutions to projects requiring reliable ball float valves.

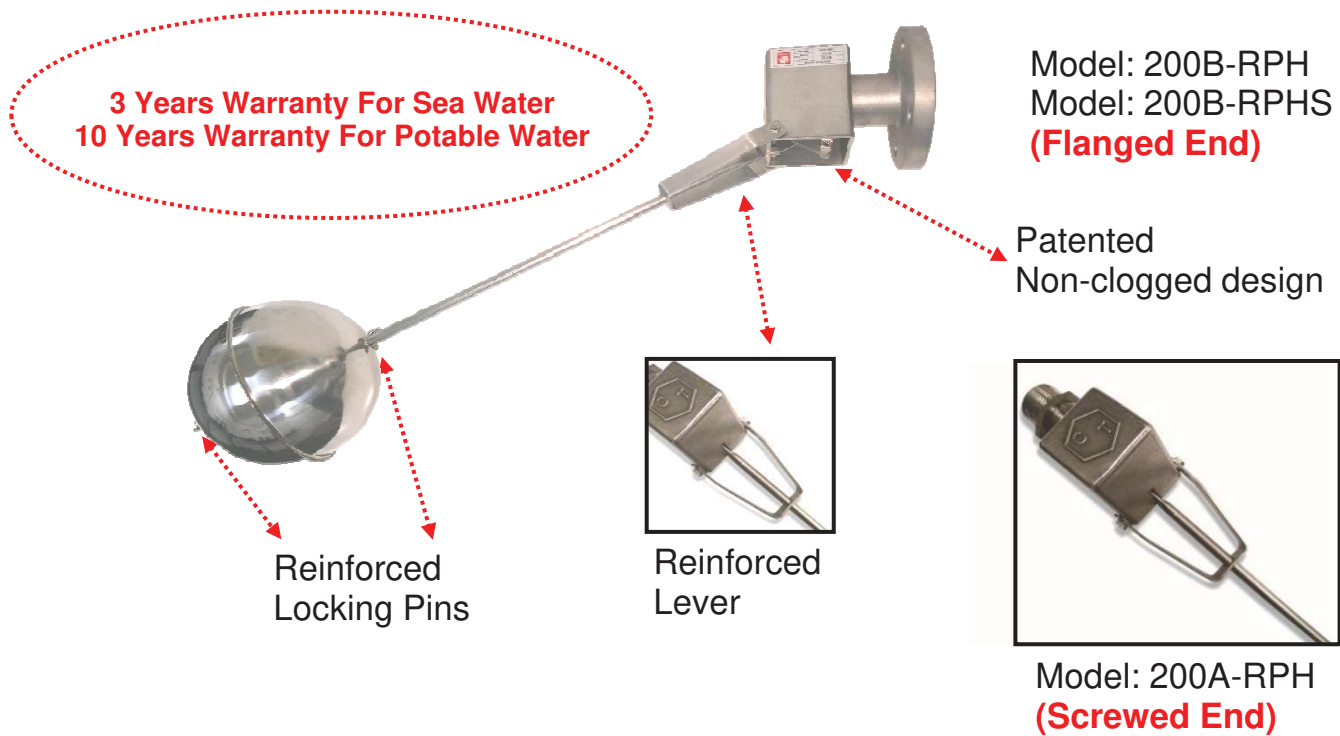

Design Feature

Patented Lock Design :

-- Equilibrium Lever arm principle with swing shutter minimizing force from the float ball.

Full Bore and Non-clog Design :

-- 100% unrestricted flow area allows passage of large solids minimizing the potential for clogging.

Reinforced Lever :

-- Special reinforced lever design ensures no swinging under operation.

Reinforced Locking Pins :

-- Float Rod penetrated through float ball with special reinforced St.St.316 locking pins, provides 100% safety to holding the float ball.

Replaceable Resilient Disc :

-- Ensures complete seal and silent operation. Easy for replacement / maintenance.

All 316 S.S. construction (Model:200B-RPH / 200A-RPH)

Duplex S.S. body with all 316 S.S. construction (Model: 200B-RPHS)

-- Suitable for potable water and different kinds of corrosive fluids, such as sea water

Model: 200A-RPH

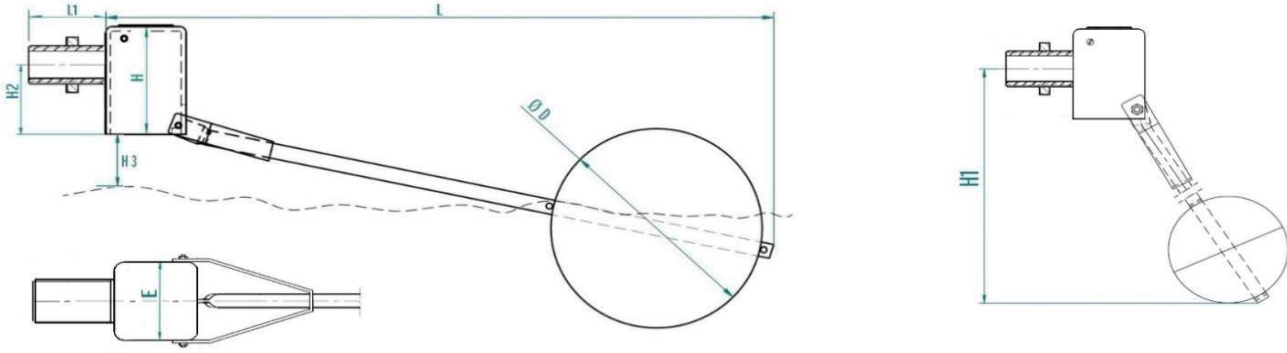

Model: 200B-RPH / 200B-RPHS

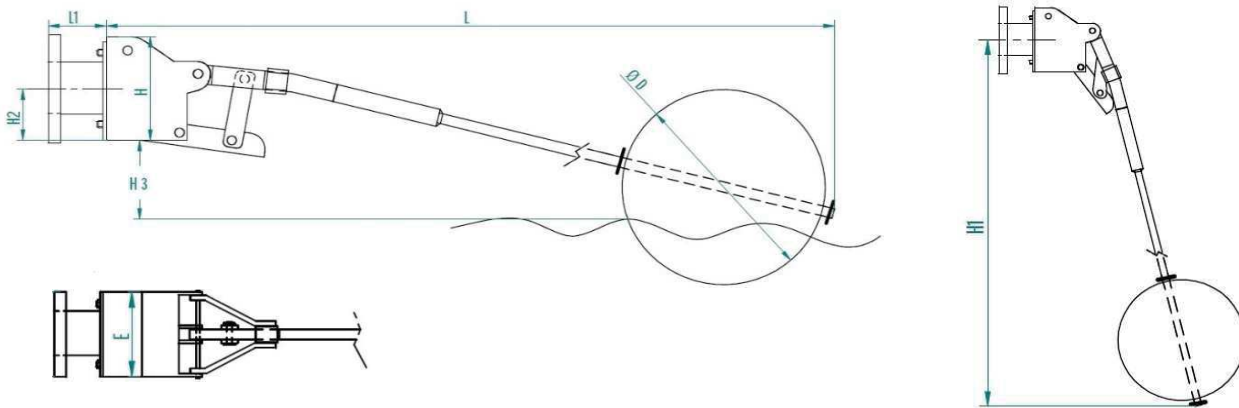

Opening [mm]	DIMENSIONS [mm]								MASS Without Float Ball [kg]	ØFloat Ball For Pressure up to 16 bar** Ø [mm] / Fig.	
	Fig. 200A and Fig. 200B										
	L	L1	ØD	E	H	H1	H2	H3			
20	500	45	160	46.5	63.5	450	32	115±*	0,989	160	200A
25	590	47	160	46.5	63.5	536	32	115±*	0,990	160	200A
32	590	53	160	46.5	63.5	536	32	115±*	0,991	160	200A
40	890	59	200	86	121	855	65	125±*	0,992	200	200A
50	890	71	200	86	121	855	66	125±*	0,993	200	200A
50	810	73	200	65	121	760	65	125±*	0,993	200	200B
80	1050	100	400	100	195	950	100	280±*	0,995	400	200B
100	1200	100	400	100	195	1050	100	320±*	0,996	400	200B
150 [#]	1350	200	400	100	195	1320	100	360±*	0,997	400	200B

#Reduced bore type.

*H3 is mean figure, which will be changed according to fluid pressure.

**Normal pressure 16 bar, maximum variable pressure 10 bar (on flow conditional).

Flange connection to PN16, DIN2576

***香港只有因80MM-150MM咸食水存貨

Opening [mm]	Water Flow vs Pressure									
	FIG. 200A and Fig. 200B									
	2 bar		4 bar		6 bar		8 bar		10 bar	
	l/s	m ³ /h	l/s	m ³ /h	l/s	m ³ /h	l/s	m ³ /h	l/s	m ³ /h
15	1,11	4,00	1,57	5,65	1,89	6,80	2,22	7,99	2,48	8,93
20	1,90	6,84	2,69	9,68	3,28	11,81	3,89	14,00	4,25	15,30
25	2,76	9,94	3,91	14,08	4,77	17,17	5,46	19,66	6,10	21,96
32	2,96	10,66	4,19	15,08	5,12	18,43	5,86	21,10	6,54	23,54
40	6,10	21,96	8,64	31,10	10,46	37,62	12,13	43,67	14,31	51,52
50	9,41	33,88	13,16	47,38	15,50	55,80	18,76	67,54	20,97	75,49
65	9,88	35,57	13,82	49,75	16,86	60,70	19,70	70,92	22,02	79,27
80	14,63	52,67	20,70	74,52	25,35	91,26	29,27	105,37	32,17	115,81
100	24,16	86,98	34,17	123,01	41,84	150,62	52,02	187,27	54,02	194,47
150	25,85	93,06	36,56	131,62	45,19	162,68	56,18	202,25	58,34	210,02

Materials :

Body	Model: 200A-RPH / 200B-RPH 316 Stainless steel (BSEN10088-1 Gr.1.4401)
	Model: 200B-RPHS Duplex Stainless steel (BSEN10088-3 Gr.1.4462)
Disc seat cover , Lever, & all Internal Parts	316 Stainless steel (BSEN10088-1 Gr.1.4401)
Float ball	316 Stainless steel (BSEN10088-1 Gr.1.4401)*

* When used in corrosive fluids, 316 stainless steel float ball can be coated with additional epoxy resin upon request



Rda. Shimizu nº nave 4
Pol. Ind. Can Torrella
08233 Vacarisses – Barcelona - (España)
Tel. +34 938 280 444 – Fax. +34 938 280 450
E-mail: comercial@valvulasct.com
info@valvulasct.com

www.valvulasct.com

Medalla de bronce
BRUSSELS EUREKA
SALON MONDIAL DE L'INVENTION 1986



Warranty

Valvulas CT warrants Model: 200B-RPH / 200A-RPH / 200B-RPHS ball float valves against defect in material or workmanship as follows :

1) Parts: Valvulas CT will provide free new or rebuilt replacement parts for 10 years of drinking water applications or 3 years of seawater applications in exchange for defective parts*. If the product is used in applications other than those recommended by Valvulas CT, or if improper maintenance or operation is performed, the warranty will be void.

2) Labor: The customer should send the defective valve to our authorized local agent repair shop for repair or pay labor costs to the local technician authorized by Valvulas CT to disassemble the valve and repair it at the work site.

3) Liability: Valvulas CT shall under no circumstances accept claims for third party liability or damage caused by the failure of any of the company's products. Also, Valvulas CT shall accept no liability for product failure caused by abnormal operation conditions, war, violence, storm, cataclysm, or other cause of force majeure.

*The replaceable resilient disc will be supplied, at no charge, only when it is found any abnormal crack or damaged caused leakage within our warranty period. If the resilient disc is damaged by any impurities inside the fluid, customer should pay for this replacement.

The decision of Valvulas CT in relation to any claims or disputes over the warranty is final.



Sole Agent:

InLok Engineering Company Limited

Mobile:3757 5614

Email: Info@inlokeng.com

Website: <https://www.inlokhk.com/>